



de Chablis  
SIRET 447 617 291  
00011 APE 9312Z

## SPELEO-CLUB DE CHABLIS

*Association loi 1901 – Statuts déposés à la Préfecture d'Auxerre n°4300 le 21 janvier 1971*

*Affilié à la Fédération Française de Spéléologie n°B-89-002 depuis 1971*

*Agrément Jeunesse et Sports n°89S83 du 10 décembre 1973*

*Déclaration Etablissement d'Activités Physiques et Sportives n°ET00160 du 25 avril 2001*

Site Internet : [www.schablis.com](http://www.schablis.com)

# CAVING IN OTAVI MOUNTAINS – OTJOZONDJUPA REGION – NAMIBIA

## FEBRUARY 2013



## Introduction

As we were 4 members of **Spéléo-Club de Chablis** to visit Namibia during holidays this February 2013, we were wondering about existing caves in this country. After some researches on the internet, we found information's about the "Caving triangle", a karstic area located between Tsumeb, Grootfontein and Otavi.

We found reports of Namgrows expeditions, organized in 2011 and 2012 in this area by Gérald FAVRE (Geologos SA and Société Spéléologique Genevoise) and Alessio FILECCIA (G.S.CAI Vittorio V and G.S. Arianna, Treviso). We got in touch with Gérald FAVRE and the Sarel and Leoni LACANTE – PRETORIUS family, the owners of the Harasib farm where are located the Dragon's Breath and Harasib underground lakes, to be able to visit those caves

## Timeline

**Monday the 18th**, we meet Mrs. Leoni Pretorius, the owner of Harasib farm in Tsumeb and she kindly authorized us to visit the caves located on her property. Then we settle down at Ghaub guest farm, located nearby Harasib farm. We are welcomed by Mika, the manager.

**Tuesday the 19th**, in the morning, first visit at Harasib farm. Martinez show us where the caves are located and also the storage room for the material Gérald kindly authorized us to use. We pick up ropes, bags and carabiners necessary to visit those caves.

In the afternoon, after a violent rain and under a crushing heat, we start to install ropes in Harasib cave but we stop at the top of the last well because of lack of hanger that fit on 10 mm studs in place.

**Wednesday the 20th**, in the morning, we return at **Harasib cave** to finish the equipment, thanks to 2 hangers enlarged by drilling to fit on the 10 mm studs. Jérôme and Loïc reach the bottom where a beautiful lake is located. We take pictures and measure the water level and temperature before taking a boat ride on the crystal waters of the lake.

**Time of exploration: 4H00**

**Depth of exploration: about - 90 m**

In the afternoon, we go to **Dragon's breath**. The heat is still crushing (about 35°C). The installation of ropes is easy because of the presence of many studs and hangers.

The platform above the lake is quickly reached and we inflate our boat in order to go on the lake. But we notice that the water level is very high and the ceiling is low above the lake surface.. The so called "beach" place is under the water, it is yet impossible to reach a dry land but we navigate all around this huge underground lake.

We make measurements of water level and temperature, and take some photos.

**Time of exploration: 3H30**

**Depth of exploration: about - 60 m**

**Thursday the 21th**, in the morning, we return to Dragon's Breath to measure the water level with a wire in the old pumping drill, but unfortunately, we don't detect the water surface.

We then bring back the material (ropes, carabiners, bags) at the dedicated room in the farm. It's time to leave, our return flight is planned on Saturday.

## Overall view of the area

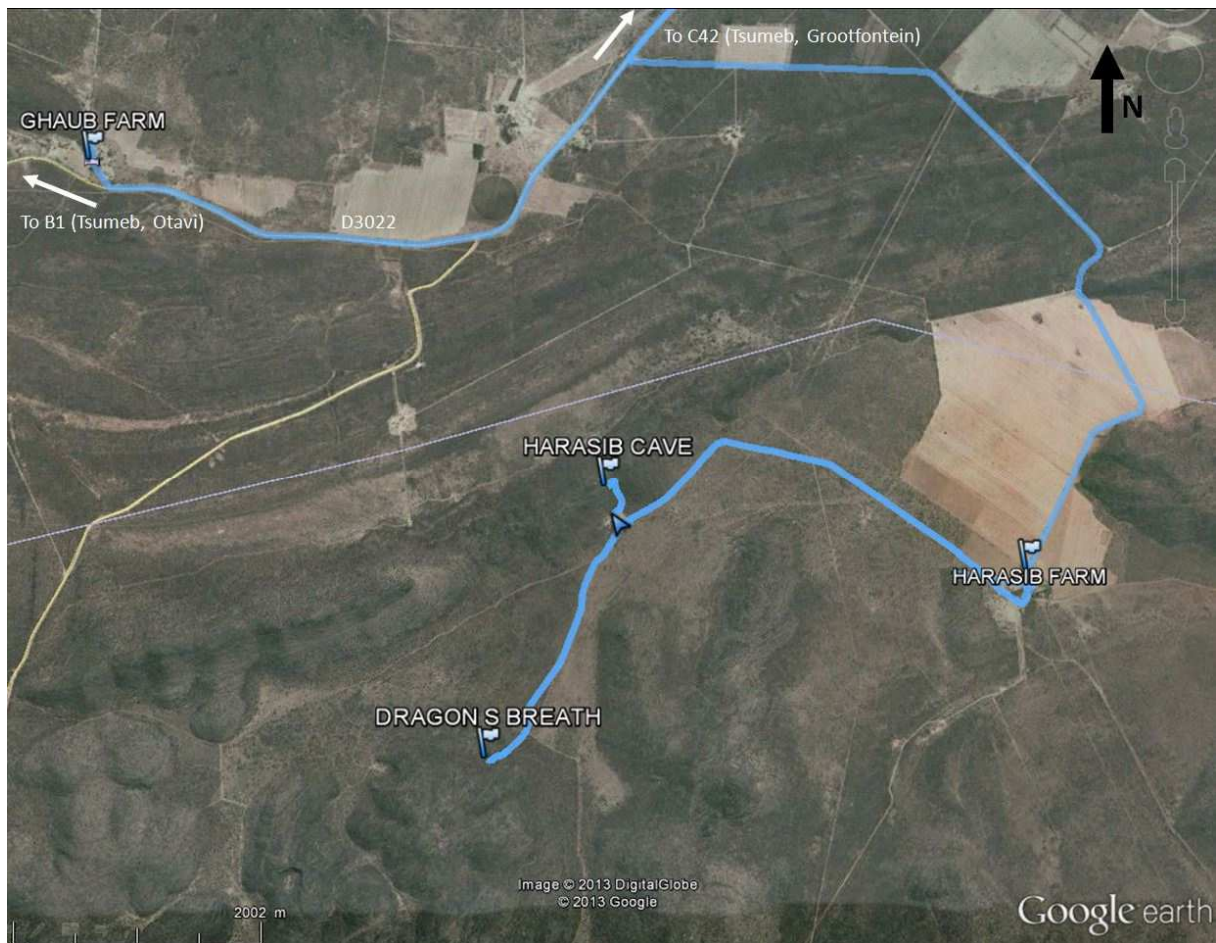

## Conclusions

Caving in Namibia is a real unique experience, very different from caving in Europe, firstly because of the underground temperature much more heat than we use to know, secondly regarding the type of caves. The 2 caves we visited have huge lake at their bottom, and Dragon's breath, with it's about 26 000 sqm surface is probably the largest underground lake of the world, and maybe the deepest.

During our explorations, we noticed water level of both lakes significantly higher than level reported in previous survey (2007, 2011 and 2012). Explanation could be important rain falls in the 2012 summer (nov. 2011 – march 2012), about 900 mm in the area, while mean rain fall is about 600 mm, and also few use of groundwaters for farm use, because this water is only used to give to drink to cattle, not for cultures.

This summer 2013 (from nov. 2012 to 21 feb. 2013) is very dry, only about 320 mm of rain falls recorded, so it will be interesting to check the evolution of water levels in both lakes in the future months.

Another point will be interesting to explain is the significant difference of conductivity of water in Harasib at 629 micro Siemens / cm and Dragon's at 400 micro Siemens / cm.

We'd like to thanks Mrs Leoni PRETORIUS for her welcome on his farm and also Mr. Gérald FAVRE for his advices and for authorization to use its equipment, and all people that we met in Harasib and Ghaub farms: Martinez, Mika, ...



# Appendix 1: Harasib cave exploration report

GPS coordinates of Harasib cave entrance hole:  
WGS84 geodesic system, Garmin eTrex30 device:

S19° 29' 48".8E 17° 47' 34".3      Z = 1643 m  
S 19.49688°   E 17.79286°      Z = 1643 m



*Harasib cave situation*

## Equipment sheet :

Way located near the old pump, along the path at the east edge of the entrance hole. This way is equipped with 8 and 10 mm studs. Appropriate nuts and hangers have to be taken. Notice that there is another way at the west edge of the entrance hole, which is equipped with in place metal ladder.

Obstacle	Rope	Anchor	Remark
1st well	C40	Handrail on tree, then a 8 mm stud and small tree at the top of the well.	10 meters handrail then 10 meters well
2nd well		Fractionation on a tree (2 sangles) or deviation on another tree to manage punctual friction area.	15 meters well

3rd well	C55	2 x 10 mm stud at the head	51 meters well
Lake	-		Presence of 2 rafts on the lake.

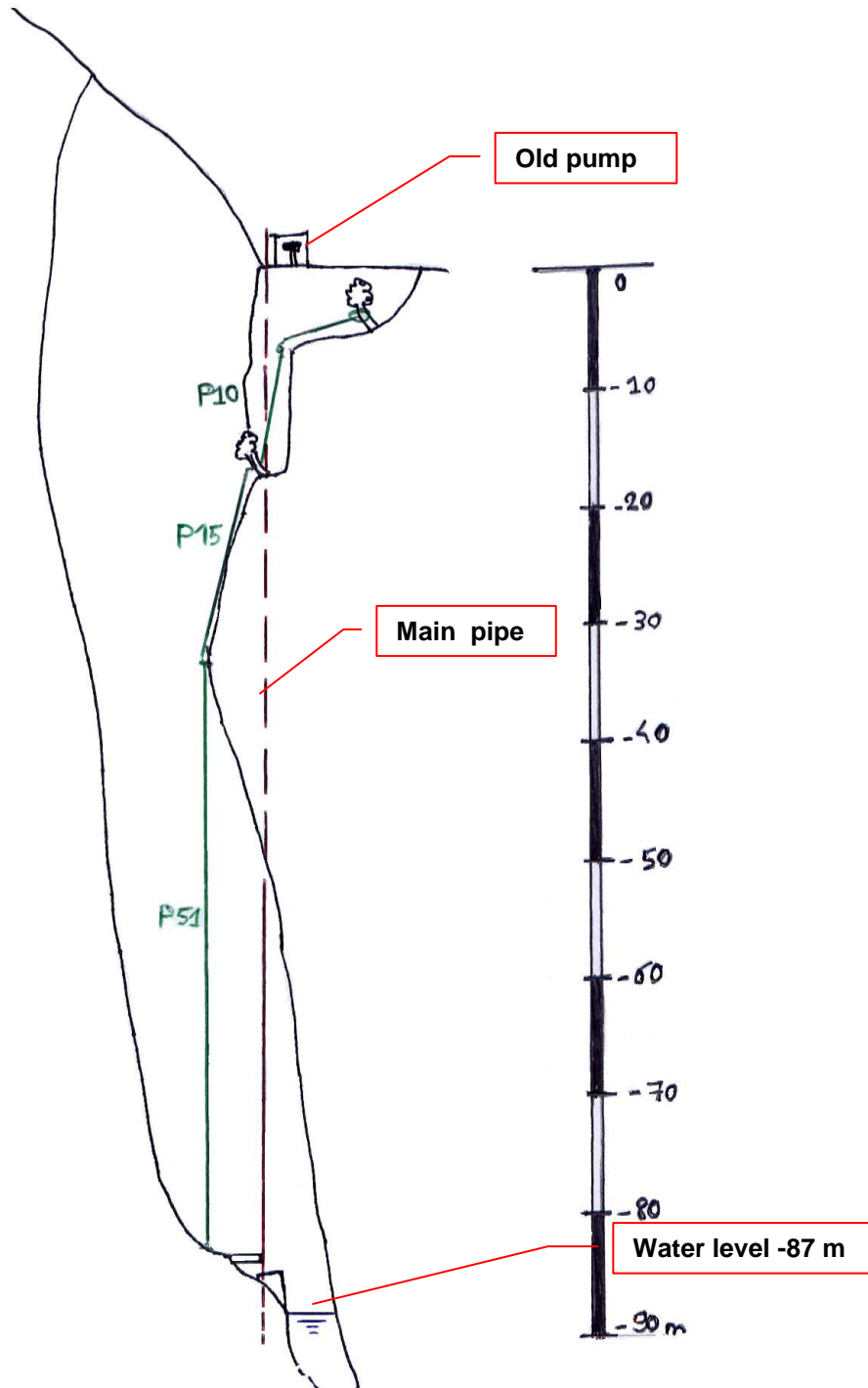

*Harasib cave exploration sketch: Section view, by loïc OFFREDO*

**Physical measures in the lake:**

Water temperature: 22.9 °c  
 Conductivity: 629 micro Siemens / cm

## Water level measures:

Different measures have been done in the area where pipe plunge in the lake, using a double decameter. As a synthesis result, we found that water level is at **-87 m** from surface (old pump level).

As a confirmation check, if we consider that water level offset between Harasib and Dragon's lakes is +11m (constant offset noticed between sept. 2010 and june 2011, see Namgrows article from Alessio Fileccia, from "Actes du 13e Congrès Suisse de Spéléologie, 2012 page 85, fig. 9"), and water level of Dragon's breath is 1546 m asl (see page 8), water level of Harasib lake should be  $1546 + 11 = 1557$  m asl, so Harasib lake depth from surface =  $1557 - 1643$  m = **-86 m** that is coherent with our measure.

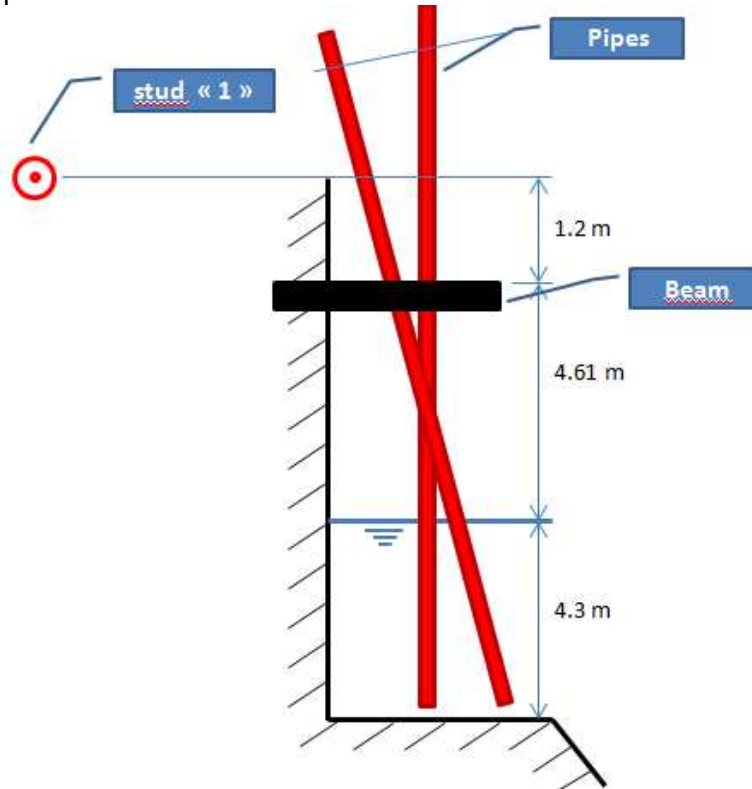

Sketch with measures that we have done







*View of reference points from where water level was measured*

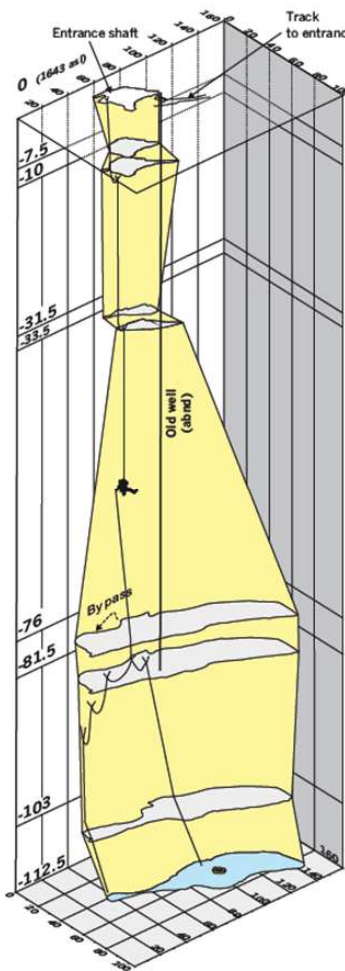

### Harasib cave

3D sketch  
(horizontal sections  
at different levels)

### Lake bottom profile

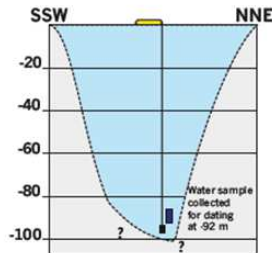

The lake profile is only approximate and based on visual inspection of the bottom and 5 soundings along maximum length (Vertical scale greatly exaggerated)



### Harasib cave (Plan view)

Position: Otavi mountainland, Harasib farm (Namibia)  
Local name: Lyon's breath  
Entrance elevation (asl): 1643  
Total depth: 112.5 m (above water), 101 m (below water)  
Lake extension 0.2 hectares  
Date of survey: 6/2/2007  
Survey team: Fersuoch Andrea, Fileccia Alessio, Tormene Giuseppe

Drawings: Alessio Fileccia  
Precision of survey: BCRA 5/C (compass, clinometer, laser, lake contours based on visual inspection and 5 soundings with weight and line)

Lithology: calcareous dolomite  
Notes: used for water abstraction in the '50s  
Caving groups: CAI, Vittorio Veneto, Arianna (Treviso, Italy)  
Notes: water sample collected for age determination at -92 m

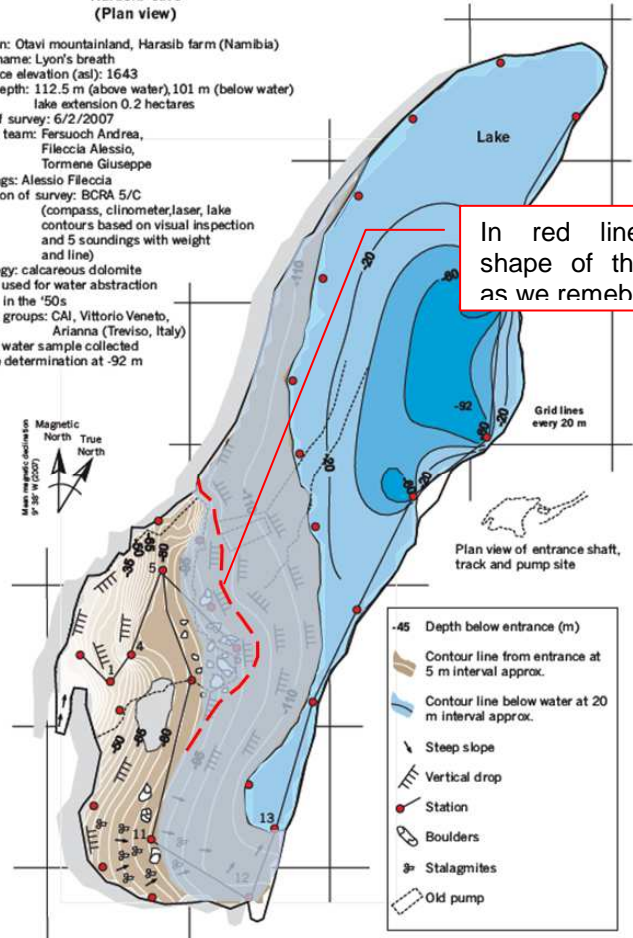

In red line, the shape of the lake as we remember it

### Hypotesis of water level in Feb. 2013 reported on 2007 Fileccia's survey (FILECCIA, 2007)

Based on Harasib cave topography of Mr. Alessio Fileccia (on which water level was at -112.5 m in 2007), we tried to report the water level of -87 m following level lines, but the result is not corresponding to what we saw, especially the shape of the lake is shrinker in some area, as we tried to sketch (in red line).

So we think that real water level depth and shape has to be confirmed with detailed topography of the cave.



**Biospeleology:**

Important groups of bat have been seen, particularly in the north and south edge of the lake (dark places)



*Frog (at the bottom of last well)*



*Bat (at north edge of lake)*



*Bat (at north edge of lake)*

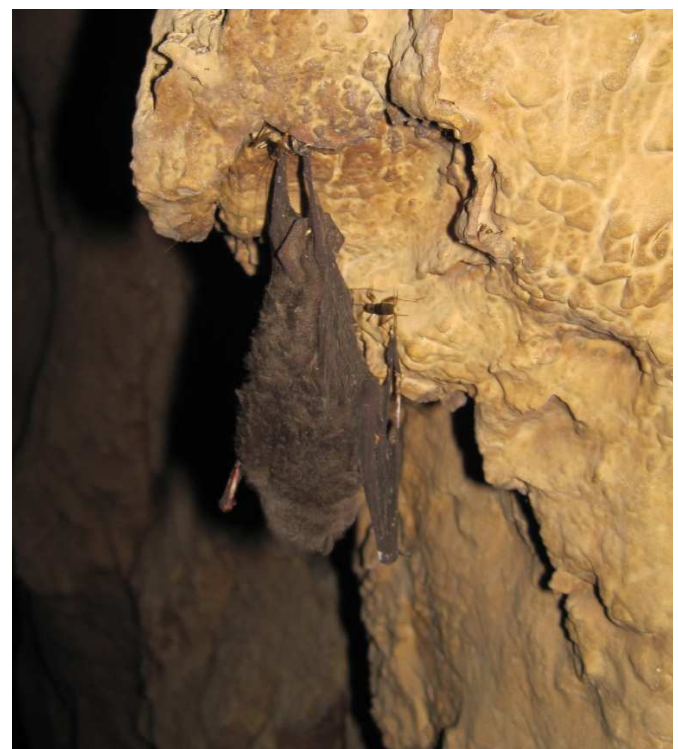

*Bat (at south edge of lake)*



**Photos:**

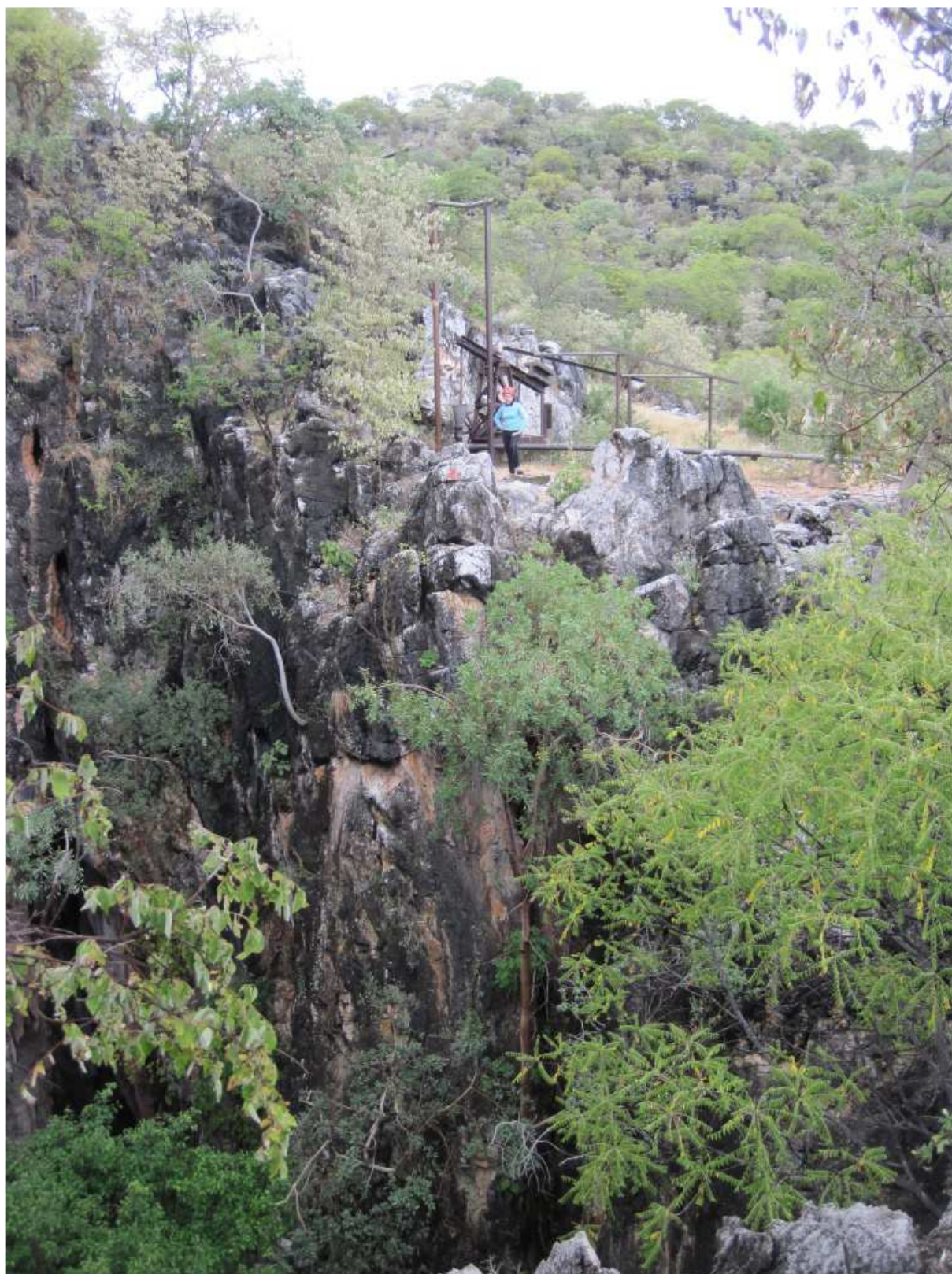

*Harasib cave entrance*





*The old pump*



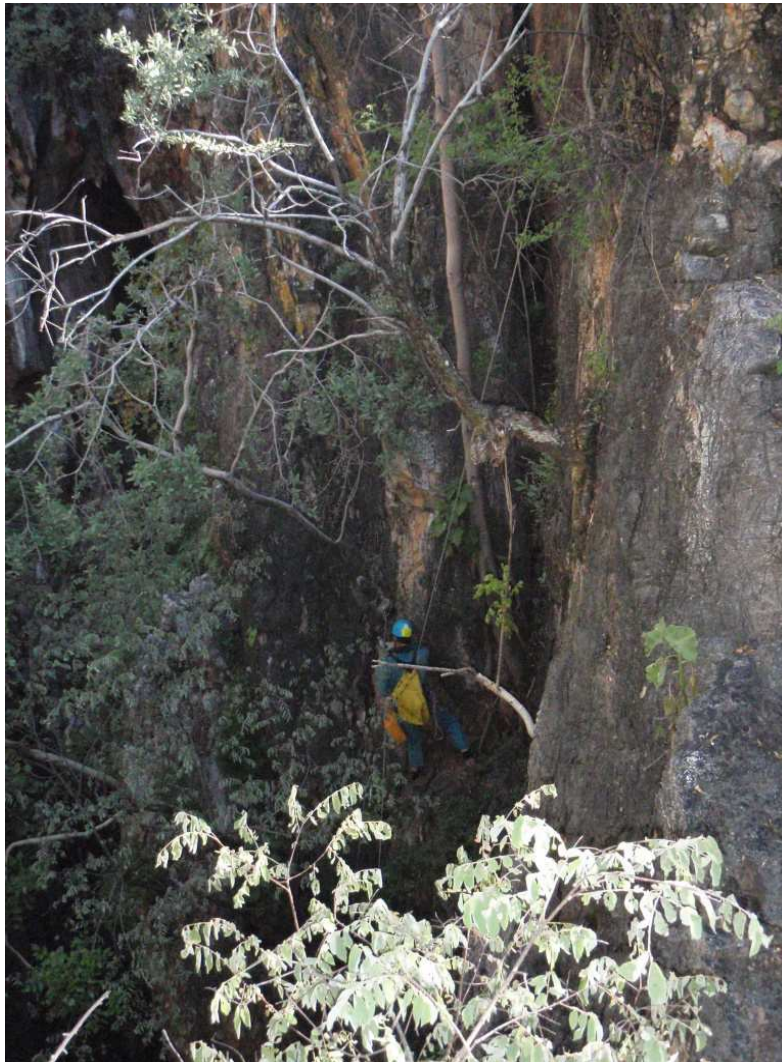

1<sup>st</sup> well (10m)



Jérôme at the head of P51

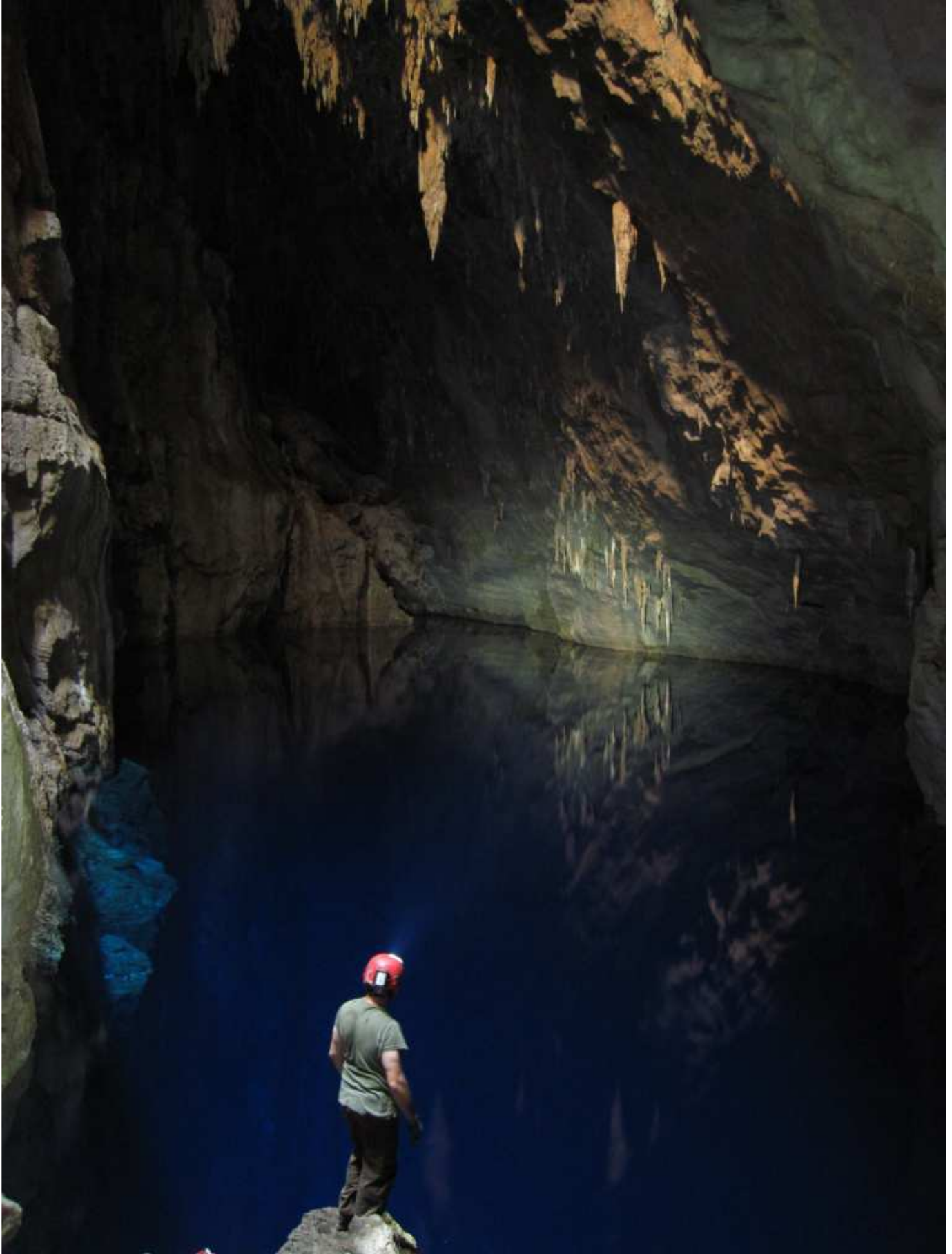

*A view on the lake, North side (from middle)*



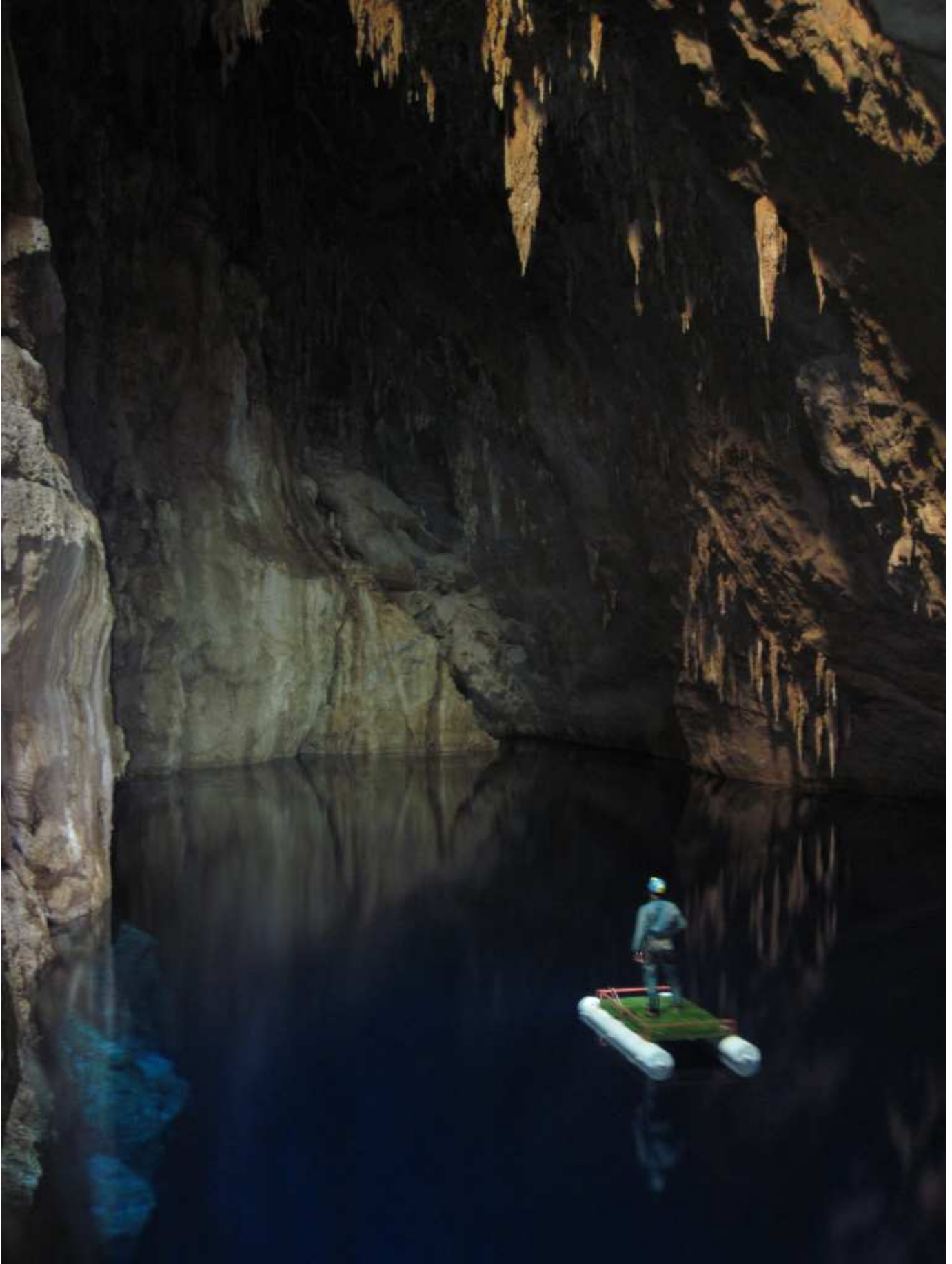

*A view on the lake, North side (from middle)*



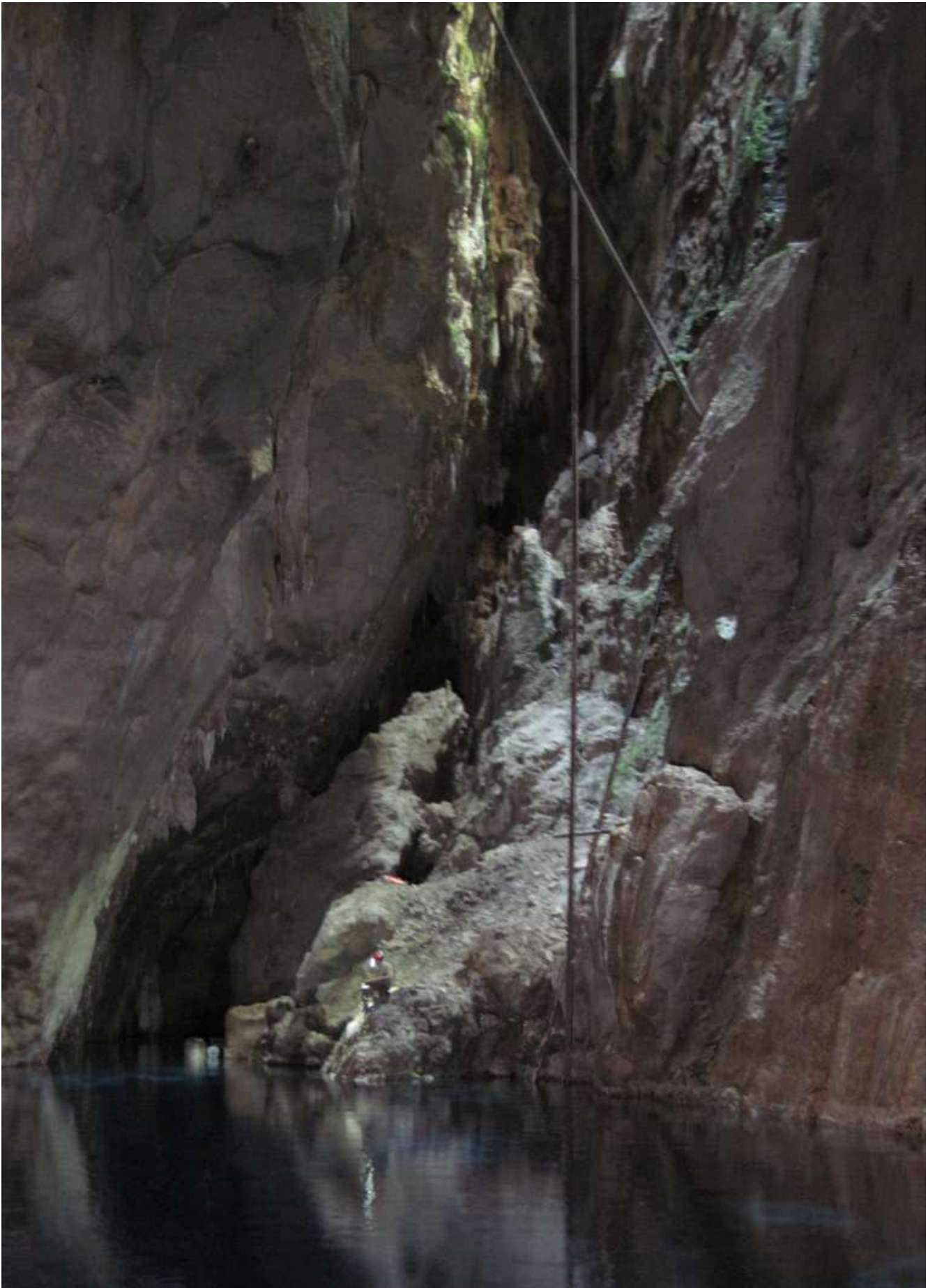

*A view on the lake, South side (from north)*



*A view on the lake, North side (from south)*



## Appendix 2: Dragon's breath cave exploration report

GPS coordinates of Dragon's breath cave entrance:  
WGS84 geodesic system, Garmin eTrex30 device:

S 19°31'1.57" E 17°47'0.22"      Z = 1596 m  
S 19.51710° E 17.78340°      Z = 1596 m

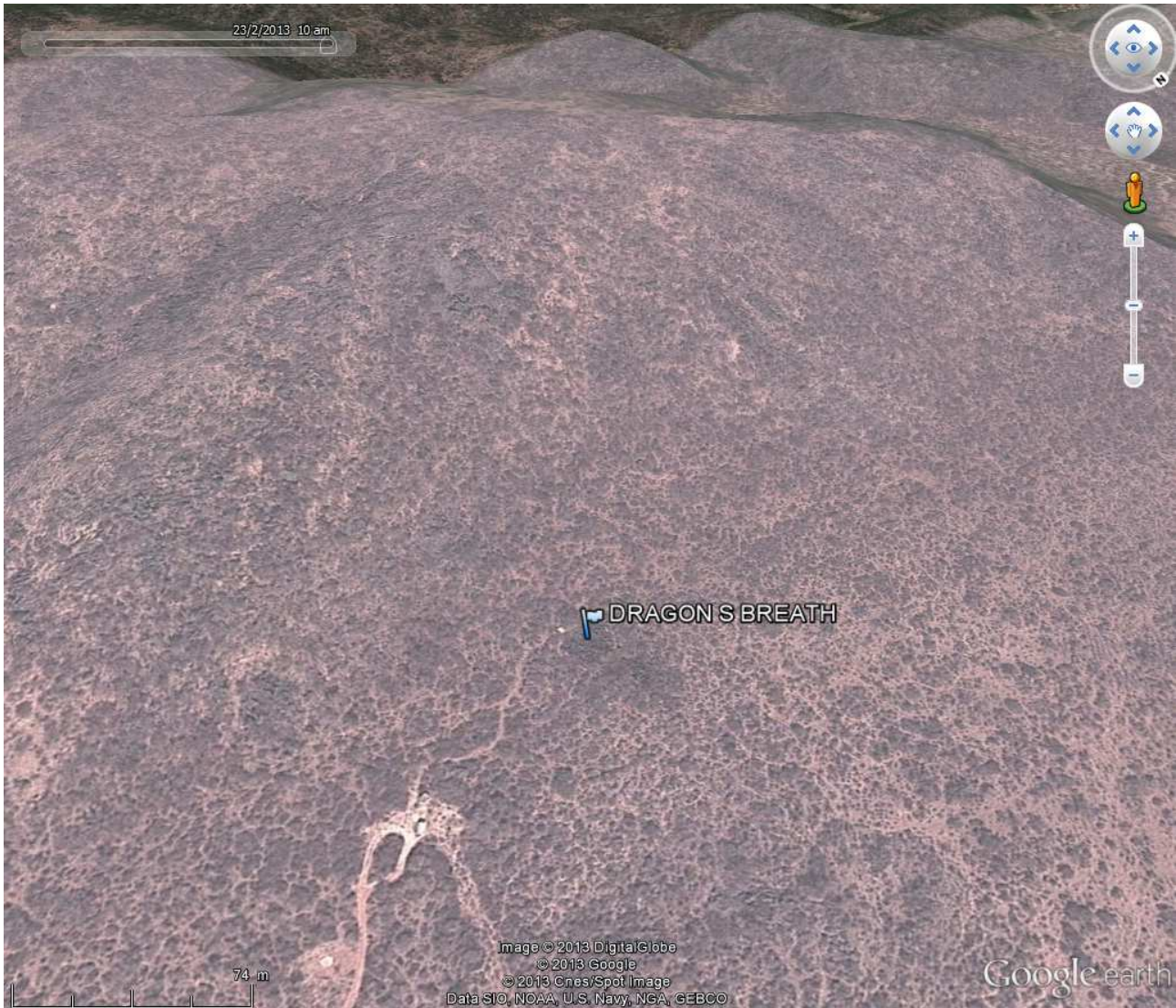

*Dragon's breath situation*

### Equipment sheet :

Obstacle	Ropes	Anchors	Remark
1st well	C10	2 x 8 mm studs	A metal ladder is already in place, rope is not mandatory.
2 meters fall			No equipment needed.
2nd well	C30	Handrail on 2 hangers in place, 2 other hangers at the top of the well. Deviation on in place hanger. Fractionation on 2 x 8 mm studs	



3rd well till platform	C50	2 x studs 8 or 10 mm	A 40 meters rope can be ok if water level is high, as when we visited the cave: level at 1546 m above the see level.
3rd well ; from plateform to lake surface		Handrail on metallic plateform then last descent to reach the lake : 4 studs 8 or 10 mm.	
Lake			Boat are needed and if possible additional powerful lightings

**Physical measures in the lake:**

Water temperature: **24.5 °c**  
 Conductivity: **400 micro Siemens / cm**

**Water level measures:**

Measures have been done from the platform just above the lake using a double decameter. As a synthesis result, we found that water level is at **-50 m** from surface and **+1546 m** above see level (entrance considered at 1596 m asl and platform at 1554 m asl).  
 In comparison, water level was -68.12 m in sept. 2010 and -61.6 m in june 2011 (cf. Namgrows 2011)

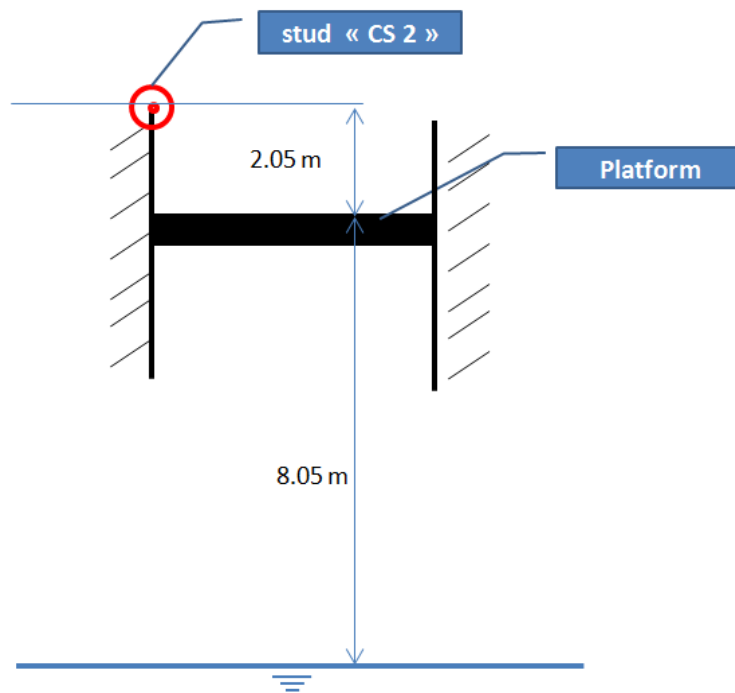

*Sketch with measures that we have done*

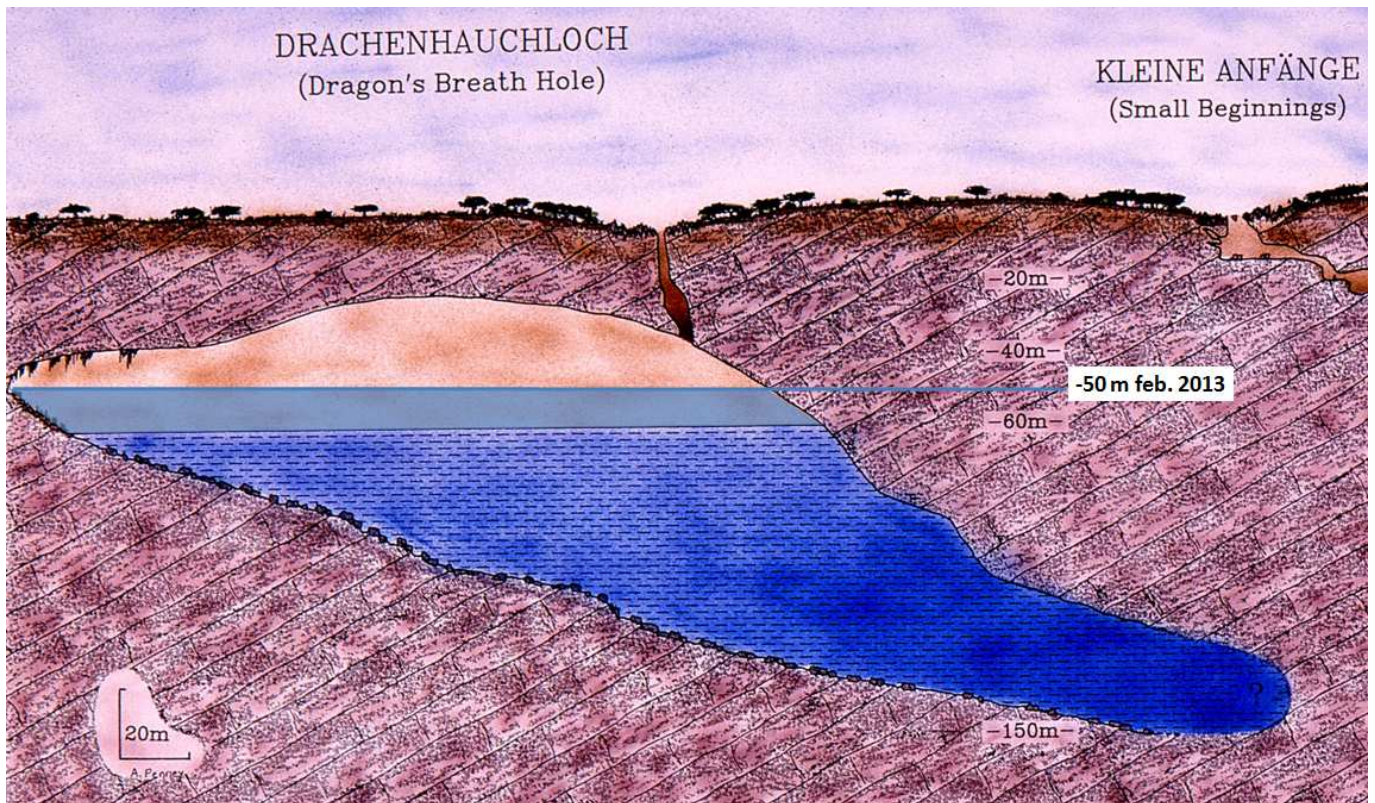
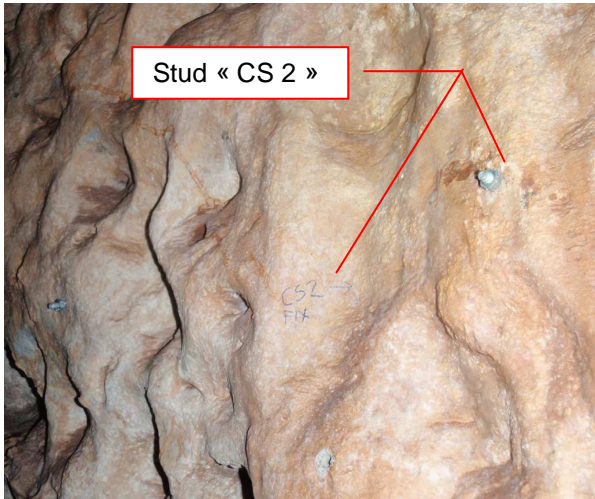

Water level in feb. 2013 reported on existing section view (Unknown author, 1987)



**Biospeleology:**

Several bats have been seen in this cave, especially at the lake level and around the platform. We saw also several spiders and other animals in the area between 1<sup>st</sup> and 2<sup>nd</sup> well (entry area).



*Bat*



*Beetle(female rhinoceros ?)*



*Desert iule (Diplopoda)*



*Scorpion*



Photos:



*Florence falls from platform to the lake's surface*



*Florence falls from platform to the lake's surface*





*Florence and Jérôme are ready to cruise*



*Jérôme fall from the platform to the lake*





*Almost flooded concretions on the lake*









*Dragon's breath entrance*

# Bibliography

External bibliographical references mentioned in this report:

FILECCIA, Alessio. 2012. « NAMGROWS Namibia ground water systems, Euro African joint cave expedition » In : Actes du 13<sup>ème</sup> congrès Suisse de spéléologie (Muotathal, 29.9 – 1.10.2012), 6 pages

FILECCIA, Alessio. 2007 « Harasib cave survey », in Plongee Sout' Mag #7 (dec.08 / may.09) Page 20, <[http://plongeesout.com/plongeesout/plongeesout\\_mag/Mag\\_n7.pdf](http://plongeesout.com/plongeesout/plongeesout_mag/Mag_n7.pdf)>, 48 pages

Unknown author. 1987 « Dragons Breath survey section » In: <[http://www.darklife.co.za/Cave\\_Pictures/Andrew\\_Penney\\_Collection/Namibia/](http://www.darklife.co.za/Cave_Pictures/Andrew_Penney_Collection/Namibia/)>

---

## Participants from Spéléo-Club de Chablis :

- GENAIRON Jérôme - Caver
- OFFREDO Loïc - Caver
- POLAWSKI Florence - Caver
- WILLEFERT Olivier - Caver

## Organization

GENAIRON Jérôme

## Author

OFFREDO Loïc

Equipment sheet: GENAIRON Jérôme

## Pictures

GENAIRON Jérôme, OFFREDO Loïc, WILLEFERT Olivier

## Sketches

OFFREDO Loïc

## Proofreading

BOUCHARD Bruno, FAVRE Gérald, GENAIRON Jérôme, RANNINGER Delphine, WILLEFERT Olivier

Spéléo-Club de Chablis – March, the 20th 2013